

FLAME SWITCH BC1000 SERIES

PRODUCT HANDBOOK



FEATURES

- 1) Compact design.
- 2) Plug-in wiring subbase for direct panel or DIN RAIL mount.
- 3) Safe-start check (SSC) feature prevents operation when abnormal flame condition exists at start-up.
- 4) LED indication (Power, Flame, SSC) on the front to show operation status.
- 5) Screw terminals on the front provide continuous 0~6VDC flame signal strength monitoring.

APPLICATION

The BC1000A/B series is a flame switch for intermittent operation to indicate presence or absence of a flame and to be applied in commercial or industrial burner installations. The BC1000A can also be used as a primary control for manually operated burner systems using a start/stop station.

In addition to the flame sensing functions, the BC1000A/B provides a “Safe Start” function which checks if a flame signal is present when applying power to the device. If so, the BC1000A/B holds its operation until the flame signal disappears.

The BC1000A/B can be used with a recifying flame rod or all existing non-selfcheck Honeywell UV sensors (intermittent operation only).

Contents

Application and Features	1
Specifications	2
Appearance and Dimensions	3
Installation and Wiring	4
Operation and Sequence	8
Safety Precautions	9

SPECIFICATIONS

Table 1: Model Selection Guide

Model	Rated voltage	Power consumption	Flame Response time	Flame sensor	Safety-start check output	Flame output
BC1000A0110F	115V 50/60Hz	5W	2 ± 1 sec.	Flame rod or C7012A/G	SPST (T3-4)	SPST (T2-3)
BC1000A0110U	115V 50/60Hz	8W	2 ± 1 sec.	C7027/35/44	SPST (T3-4)	SPST (T2-3)
BC1000A0220F	230V 50/60Hz	5W	2 ± 1 sec.	Flame rod or C7012A/G	SPST (T3-4)	SPST (T2-3)
BC1000A0220U	230V 50/60Hz	8W	2 ± 1 sec.	C7027/35/44	SPST (T3-4)	SPST (T2-3)
BC1000B1000	115V 50/60Hz	5W	Max. 1 sec.	Flame rod or C7012A/G	None	SPDT (T2...4)
BC1000B1018	230V 50/60Hz	5W	Max. 1 sec.	Flame rod or C7012A/G	None	SPDT (T2...4)
BC1000B2001	115V 50/60Hz	8W	Max. 1 sec.	C7027/35/44	None	SPDT (T2...4)
BC1000B2019	230V 50/60Hz	8W	Max. 1 sec.	C7027/35/44	None	SPDT (T2...4)

Table 2: Electrical and Environmental Ratings

Item	Specification
Rated voltage	110..115Vac or 220..230Vac, 50/60Hz -15 ~ +10%
Allowable ambient temperature	Stand-alone mounting: -20 ~ +60°C Parallel mounting (2 or more sets) : -20 ~ +45°C
Allowable ambient humidity	Max. 90% RH non condensing
Vibration resistance	0.5G (10 to 150Hz for 1h each in x,y and z directions)
Insulation resistance	More than 50MΩ at DC500V between terminals and ground
Life expectancy	Designed for 250.000 cycles under nominal conditions
Terminal ratings	Relay output max 1A @ cosφ=1,0 per terminal
Flame strength	Flame On : < 1V Flame Off : > 0.2V
Size (WxHxD)	42.5 x 90.0 x 95.5 mm (including sub-base)
Weight	Approx. 334g (including sub-base)

* Keep min. 50mm distance from the top and min. 20mm left/right/bottom around the device.

APPEARANCE AND DIMENSIONS

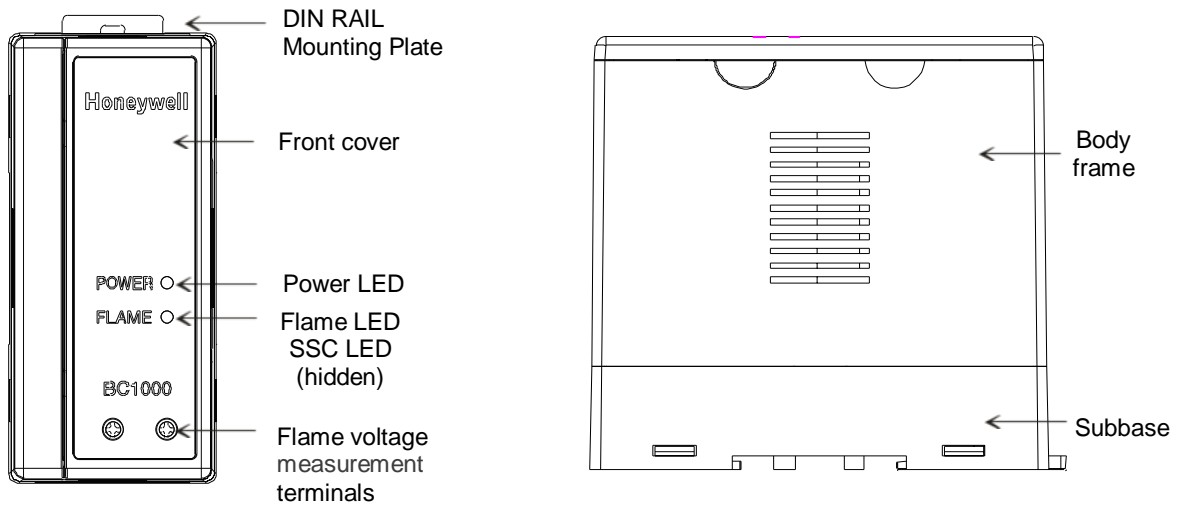

Fig. 1: Appearance

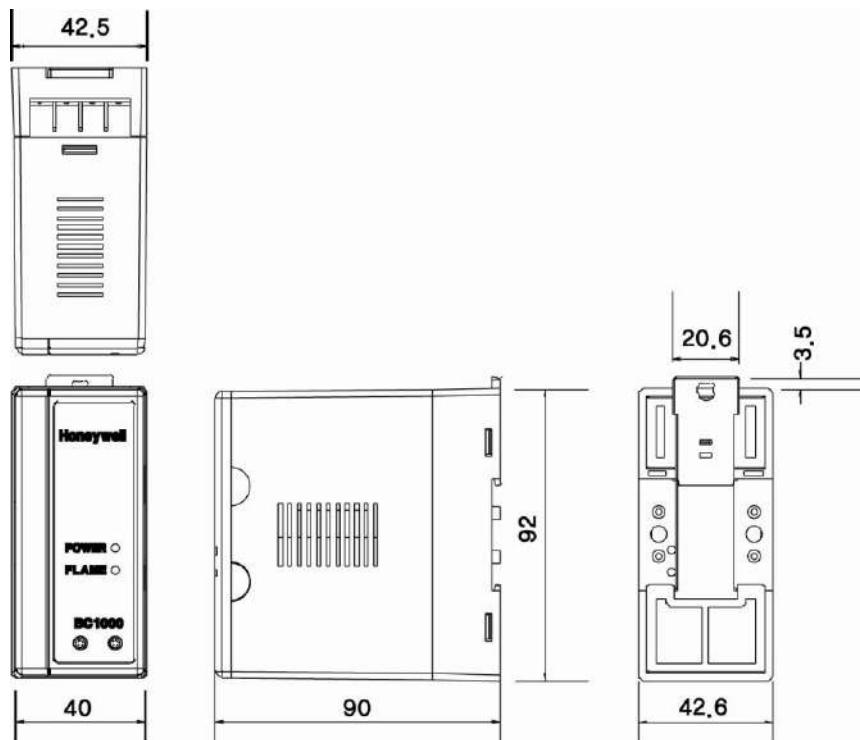

Fig. 2: External Dimensions (in mm)

INSTALLATION AND WIRING

CAUTION

- 1) Do not install the Flame Switch under any circumstances in the following locations:
 - a. Where chemicals or corrosive gases are present, such as ammonia, sulfur, chlorine, ethylene compounds, acids, etc.
 - b. Where the relative humidity reaches the saturation point. The relay module is designed to operate in a maximum 85% relative humidity continuous, noncondensing, moisture environment. Condensing moisture can cause a safety shutdown or damage the device.
 - c. Where vibration exceeds 0,5G continuous vibration or temperatures exceed the maximum specification for this device.
- 2) Disconnect the power supply from the main disconnect before beginning installation to prevent electrical shock and equipment damage. Supply power to BC1000 after finishing all wiring and completing proper checks.
- 3) Do not overload the BC1000 terminal rating.
- 4) Do not bundle the lead wires for mains, ignition transformer's HIGH-VOLTAGE and flame detector. The min. distance between the BC1000 and the HV ignition cable is 10cm.
- 5) Use proper grounding work in accordance with the engineering standards for electrical equipment.

SEPARATION AND INSTALLATION OF BODY FRAME AND SUB-BASE

- 1) Remove the front cover as shown in Fig. 1 and unscrew the Phillips head fixation screw by about 8 turns CCW.
 - 2) Hold the body frame and sub-base with both hands to pull the relay module from its socket. Don't use excessive force to avoid damage to the device.
 - 3) Place sub-base and mount by fastening screws.
- * If mounting the subbased onto DIN RAIL, refer to Fig. 4.

INSTALLATION AND WIRING (continued)

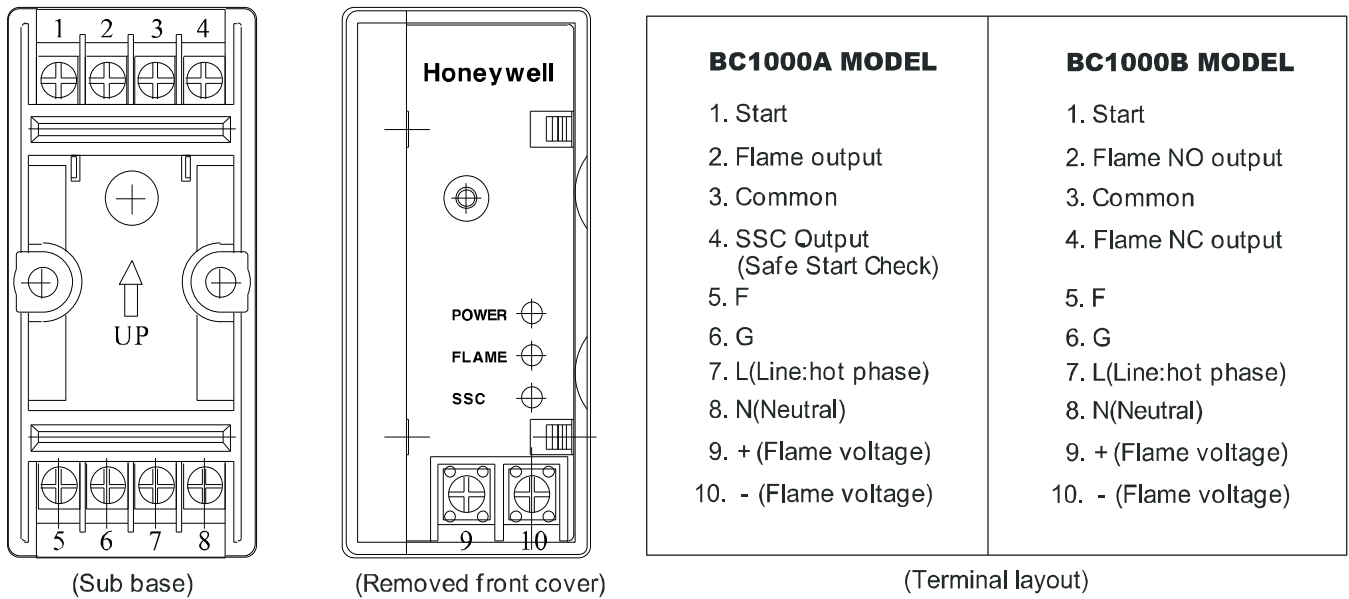

Fig. 3: Sub-base terminals and front terminals

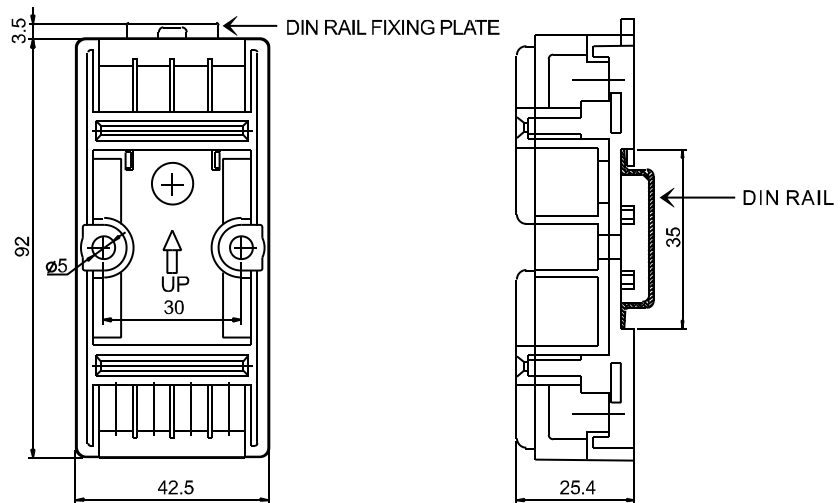
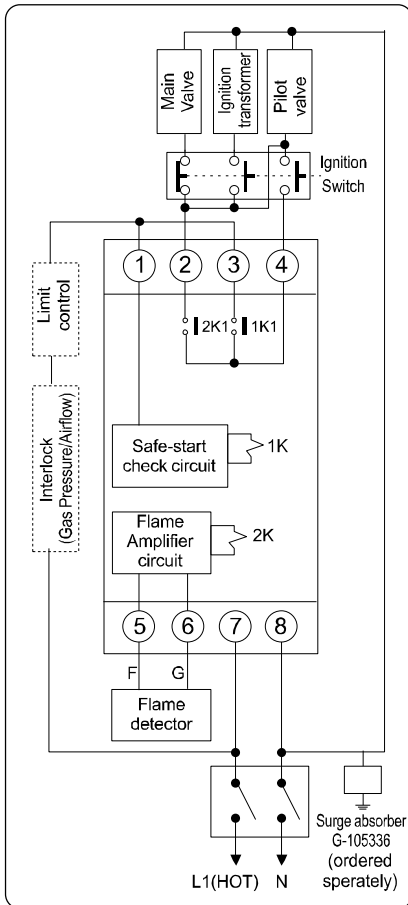

Fig. 4: Dimensions (DIN RAIL mount)

Sub-base Wiring

① Manual Ignition (Intermittent pilot)

BC1000A Model (Except BC1000B)



② Flame Monitoring

BC1000A Model

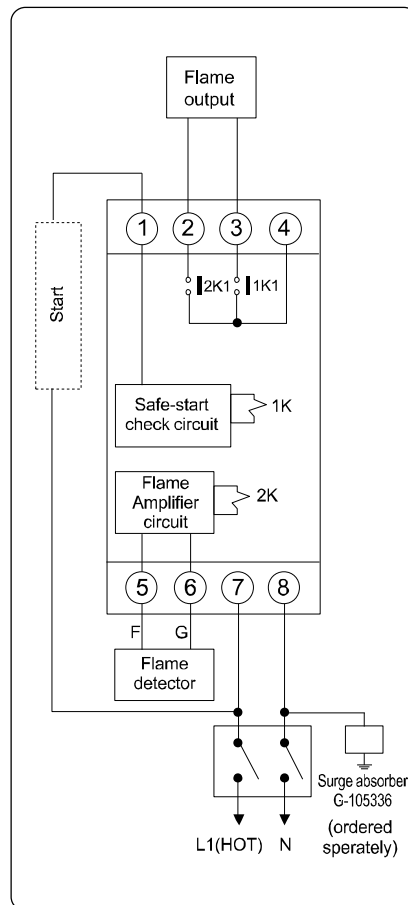

BC1000B Model

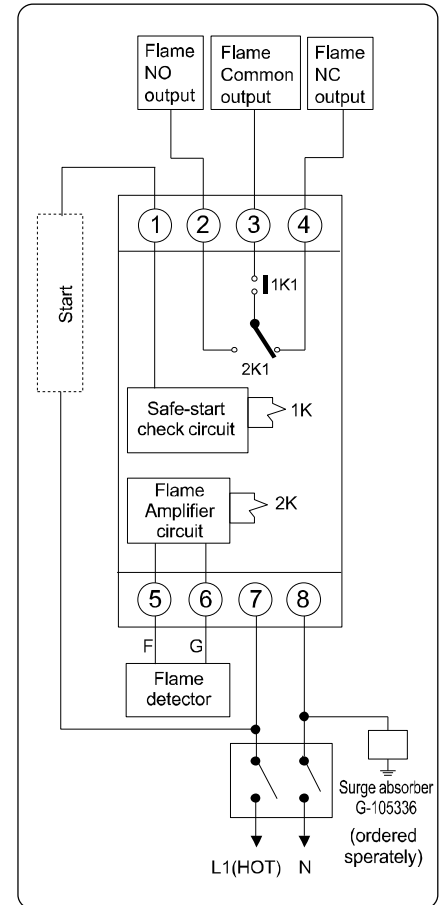

Fig. 5: Example of wiring to external devices

- 1) Fig. 5 is an example of typical wiring diagrams. Refer Fig. 2 for terminal location
- 2) Internal relay operation

BC1000A MODEL	BC1000B MODEL
<ol style="list-style-type: none"> 1. Safe-start check circuit verifies that a flame or flame simulating condition exists when powering up the terminal 1 of the device. <ul style="list-style-type: none"> - No flame: Safety relay closed (1K1 close) - Flame: Safety relay remains opened (1K1 open) until the flame disappears (hold condition) 2. Flame amplifier circuit controls the flame relay. <ul style="list-style-type: none"> - No flame: Flame relay opened (2K1 open) - Flame : Flame relay closed (2K1 close) 	<ol style="list-style-type: none"> 1. Safe-start check circuit verifies that a flame or flame simulating condition exists when powering up the terminal 1 of the device. <ul style="list-style-type: none"> - No flame: Safety relay closed (1K1 close) - Flame: Safety relay remains opened (1K1 open) until the flame disappears (hold condition) 2. Flame amplifier circuit controls the flame relay. <ul style="list-style-type: none"> - No flame: Flame relay NC output is closed (2K1 NC) - Flame: Flame relay NO output is closed (2K1 NO)

How to install the flame detector

To check the correct installation location of the flame detector, the flame signal strength can be measured using a multimeter. Connect the multimeter to the (+) and (-) terminals located at

the front. The minimum recommended voltage is 2VDC, while the maximum value is limited to 6VDC. Adjust the optimal position of the flame detector. For instructions to install Honeywell UV flame detector, refer to the instruction sheet of C7027/C7035/C7044/C7927 flame detectors.

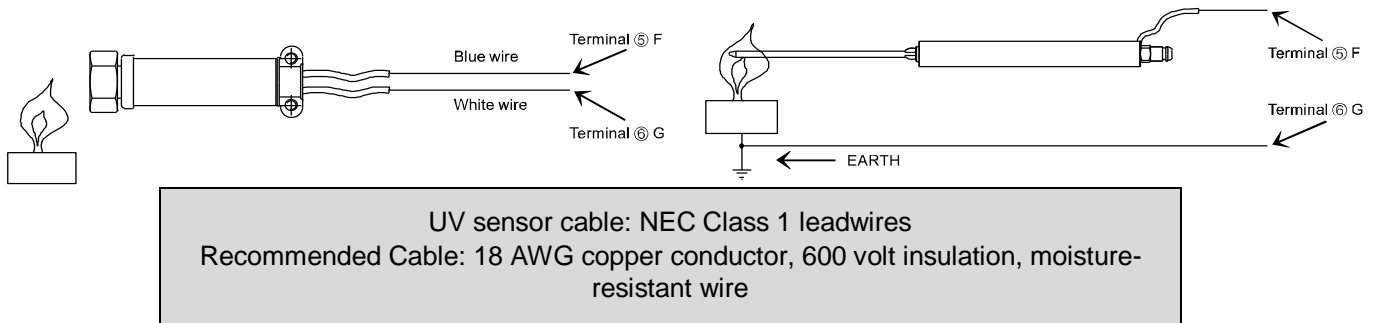

Fig. 6: Flame detector wiring

OPERATION AND SEQUENCE

a. Manual Ignition System with Intermittent Pilot (refer to Fig. 5 ①Manual Ignition)

LED DISPLAY		STANDBY	SAFE-START	PFEP④	RUN	STANDBY
	POWER	● POWER	● POWER	● POWER	● POWER	● POWER
	FLAME	○	○	● FLAME	● FLAME	○
	SSC	○	● SSC	● SSC	● SSC	○
Ignition switch				Ignition switch		
Pilot				Intermittent pilot ③		
Main Valve					Main valve ②	
limit / interlock				limit / interlock closed		
Flame signal			Safe-start check ①	Flame proving		

1. If flame is detected before safe-start check is completed, operation is put on hold until the flame signal disappears. (① in upper table)
2. If flame is lost during RUN, the flame relays are de-energized. (②③ in upper table)
3. Pilot flame establishing period(PFEP) should comply with the application standards. (④ in upper table)

b. Flame Monitoring System (normal operation, refer to Fig. 5 ②Flame Monitoring)

LED DISPLAY		STANDBY	SAFE-START	FLAME MONITORING				STANDBY
	POWER	● POWER	● POWER	● POWER	● POWER	● POWER	● POWER	● POWER
	FLAME	○	○	○	● FLAME	○	● FLAME	○
	SSC	○	● SSC	● SSC	● SSC	● SSC	● SSC	○
Flame on				②	③	②	③	
Start				Start input (Safe-start check operation)				
Flame signal			Safe-start check ①	No flame	Flame	No flame	Flame	

1. If flame is detected before safe-start check is completed, output relays are operated as below until the flame signal disappears. (① in upper table)
BC1000A Model: 1K1 relay open and 2K1 relay close (T2-T4 closed)
BC1000B Model: 1K1 relay open and 2K1 relay NO (T3-T2 & T3-T4 opened)
2. If flame is lost during operation, output relays are operated as below. (② in upper table)
BC1000A: 1K1 relay close (T3-T4 closed) and 2K1 relay open (T2-T3 opened)
BC1000B: 1K1 relay close and 2K1 relay NC (T3-T2 opened, T3-T4 closed)
3. If flame is detected during operation, output relays are operated as below. (③ in upper table)
BC1000A: 1K1 relay close (T3-T4 closed) and 2K1 relay close (T2-T3 closed)
BC1000B: 1K1 relay close and 2K1 relay NO (T3-T2 closed, T3-T4 opened)

SAFETY PRECAUTIONS



WARNING

Fire or Explosion Hazard.
Can cause severe injury , death or property damage.



CAUTION

Electrical Shock Hazard or Equipment Damage Hazard.
Can cause personal injury, or damage equipment.

Read these instructions carefully when installing this product..



Warning

- 1) Remove supply voltage at the start of the installation to prevent electrical shock and / or equipment damage.
- 2) Do not touch any terminal of BC1000 while power is present to avoid an electrical shock.
- 3) BC1000 verifies that a flame or flame simulating condition exists at start-up. BC1000 can be used in intermittent operation only, i.e a controlled stop/start must occur at least once every 24 hours of operation.
- 4) All wiring must comply with all applicable electrical codes, ordinances and regulations.
- 5) The flame failure response time of the device is "2 seconds \pm 1sec" or "max 1sec", which is in line with the European standards.
- 6) After deenergizing the BC1000, residual charge may be present on terminal 5 (F lead of the flame detector). Therefore, do not touch "F" terminal after immediately after power-off. It may cause electrical shock.



Caution

- 1) Installation, wiring, repair, maintenance, adjustment and other special works should be executed by well trained flame safeguard installers.
- 2) Apply reliable high quality timer, auxiliary relay and other devices for supplementary functions, and wire correctly.
- 3) Follow instruction manual for Installation and wiring.
- 4) Be sure loads do not exceed the terminal ratings.
- 5) When wiring C7027/C7035/C7044 UV flame detector, the white lead wire must be connected to G Terminal (Terminal 6) and the blue lead wire to F terminal (Terminal 5). Incorrect wiring may cause flame detector damage.
- 6) High-voltage cable of an ignition transformer should be physically separated and kept away at least 10cm from the BC1000
- 7) The ignition transformer must be grounded properly, following the standards
- 8) Apply the correct supply voltage to the BC1000.
- 9) Do not connect the power supply until all wiring and installation has completed and double checked for failures.

Sales Affiliates ECC OEM Europe

Germany, Austria, Switzerland, Liechtenstein

Honeywell GmbH - Harchofweg - 74821 Mosbach - GERMANY
Ph.: (+49) 6261 81 0 - Fax: (+49) 6261 81 461 - OEM-SalesCentralEurope@Honeywell.com - www.honeywell.com/sites/de

France

Honeywell SA - Parc Technologique de St. Aubin - Bâtiment Mercury BP87 - 91183 Gr-Sur-Yvette Cedex - FRANCE
Ph.: (+33) 1 60 19 80 00 - Fax: (+33) 1 60 19 81 81 - OEM-SalesWestEurope@Honeywell.com - www.honeywell.com/sites/fr

Italy

Honeywell srl - Via Philips n.12 - 20052 Monza - ITALY
Ph.: (+39) 0 39 21 65 1 - Fax: (+39) 0 39 21 65 402 - OEM-SalesSouthEurope@Honeywell.com - www.honeywell.it

Spain - Portugal

Honeywell S.A. - Josefa Valcárcel 24 - 28027 Madrid - SPAIN
Ph.: (+34) 9 13 13 61 00 - Fax: (+34) 9 13 13 61 27 - OEM-SalesSouthEurope@Honeywell.com - www.honeywell.com/sites/es

United Kingdom

Honeywell Control System Ltd. - Unit 2 President Buildings, Savile Street East - S Yorks S4 7UQ - Sheffield - UNITED KINGDOM
Ph.: (+44) 114 286 0920 - OEM-SalesUK@Honeywell.com - www.honeywell.com/sites/uk

Netherlands, Belgium, Luxembourg, Scandinavia

Honeywell B.V. - Laardershoogweg 1B-20 - 1101 EA Amsterdam Z.O. - THE NETHERLANDS
Ph.: (+31) 2 05 65 69 11 - Fax: (+31) 2 05 65 66 00 - OEM-SalesWestEurope@Honeywell.com - www.honeywell.com/sites/nl

Turkey

Honeywell A.S. - Cayiriyolu Sok. No:7 - Urogen Plaza, Kat:7 - Isarenikoy 34752 Istanbul - TURKEY
Ph.: (+90) 218 578 7120 - Fax: (+90) 218 575 6637 - OEM-SalesSouthEurope@Honeywell.com - www.honeywell.com/sites/tr

Slovakia

Honeywell s.r.o. - Mlynske Nivy 71 - PO Box 75 - 82007 Bratislava 27 - SLOVAKIA
Ph: (+421) 2 322 822 11 - Fax: (+421) 2 322 622 55 (54) - OEM-SalesEasternEurope@Honeywell.com - www.honeywell.sk

Czech Republic

Honeywell spol. s r.o. - V parku 2328/1B - 14800 Prague - CZECH REPUBLIC
Ph: (+420) 242 442 111 (255) - Fax: (+420) 242 442 181 - OEM-SalesEasternEurope@Honeywell.com - www.honeywell.com/sites/cz

Kazakhstan

Honeywell Automation Controls - 42, Timiryazev Str. - 060057 Almaty - KAZAKHSTAN
Ph: (+7) 727 2747 747 - Fax: (+7) 727 2752 252 - OEM-SalesEasternEurope@Honeywell.com - www51.honeywell.com/ru

Ukraine

IP Honeywell Ukraine - Silver Centre - 4, Kara Lepshe ave. - 03680 Kiev - UKRAINE
Ph: (+380) 44 351-15-50 (52) - Fax: (+380) 44 351-15-51 (53) - OEM-SalesEasternEurope@Honeywell.com - www51.honeywell.com/ru

Russia

ZAO Honeywell - Luzhniki 24 - 119048 Moscow - RUSSIA
Ph: (+7) 495 796 9800 (35) - Fax: (+7) 495 796 9894 (797 9370) - OEM-SalesEasternEurope@Honeywell.com - www51.honeywell.com/ru

Hungary

Honeywell Kft. - Petnehazy U. 2-4 - 1139 Budapest - HUNGARY
Ph: (+36) 1 451 4300 (46) - Fax: (+36) 1 451 4343 - OEM-SalesEasternEurope@Honeywell.com - www51.honeywell.com/hungary

Poland

Honeywell Sp z o.o. - Domaniewska 39b - 02672 Warsaw - POLAND
Ph: (+48) 22 60 80800 (50) - Fax: (+48) 22 60 80883 - OEM-SalesEasternEurope@Honeywell.com - www.honeywell.com/sites/pl

Romania

Honeywell Romania SRL - Calea Floreasca 189A - 014462 Bucharest - ROMANIA
Ph: (+40) 312 24 3000 (3) - Fax: (+40) 212 31 8439 - OEM-SalesEasternEurope@Honeywell.com - www.honeywell.com/sites/romania

